

USER'S MANUAL

GOBLIN

Electrical Load Manager/Demand Controller

This document contains the latest technical information about Goblin which is a micro-controller based Electrical Load Management/Demand controller. The unit is tested against latest "MTE" Standard Model PRS400.3 having basic accuracy of 0.02%, traceable upto International Standards derived using appropriate ratio techniques.

The product, Goblin is sophisticated electronic equipment, and the user is advised to read this User's Manual carefully before attempting to install or operate the equipment.

Published on:-----
Document Version: 1.1

Warranty statement

Trinity warrants to the original retail purchaser of the Trinity product enclosed with this limited warranty statement that the product, if purchased new and used in the India conforms to the manufacturer's specifications and will be free from defects in workmanship and materials for a period of one year from the date of original purchase, unless expressly stated otherwise by Trinity, in a written format.

Should your Trinity product prove defective during the warranty period, please bring the product securely packaged in its original container or an equivalent, along with proof of the date of original purchase, to our Trinity Dealer or Factory. You are responsible for all costs (shipping, insurance, travel time) in getting the product to the service location. Trinity will, at its option, repair or replace on an exchange basis the defective unit, without charge for parts or labor. When warranty service involves the exchange of the product or of a part, the item replaced becomes Trinity property. The replacement unit may be new or refurbished to the Trinity standard of quality, and at Trinity's option, the replacement may be another model of like kind and quality. Trinity's liability for replacement of the covered product will not exceed the original retail selling price of the covered product. Exchange or replacement products or parts assume the remaining warranty period of the product covered by this limited warranty.

What This Warranty Does Not Cover:

This warranty does not apply to refurbished or reconditioned products. This warranty covers only normal use in India. This warranty does not cover damage to the Trinity product caused by parts or supplies not manufactured, distributed or certified by Trinity. This warranty is not transferable. This warranty does not cover third party parts, components or peripheral devices added to the Trinity product after its shipment from Trinity. Trinity is not responsible for warranty service should the Trinity label or logo or the rating label or serial number be removed or should the product fail to be properly maintained or fail to function properly as a result of misuse, abuse, improper installation, neglect, improper shipping, damage caused by disasters such as fire, flood, and lightning, improper electrical current, interaction with non-Trinity products, or service other than by an Trinity Authorized Service.

The warranty and remedy provided above are exclusive and in lieu of all other express or implied warranties including, but not limited to, the implied warranties of merchantability or fitness for a particular purpose. In the event, the remedies above fail, Trinity's entire liability shall be limited to a refund of the price paid for the Trinity product covered by this limited warranty. Except as provided in this written warranty, neither Trinity Energy Systems Pvt. Ltd. nor its affiliates shall be liable for any loss, inconvenience, or damage, including direct, special, incidental, or consequential damages, resulting from the use or inability to use the Trinity product, whether resulting from breach of warranty or any other legal theory.

Contents

Introduction	4
The Main features Available in this Model	4
Technical Specifications.....	5
Installation and Commissioning.....	7
3P4W Mode Installation	7
3P3W Mode Installation	9
Connection Scheme.....	10
RS485 Connection	11
Operational Details.....	12
Programming Mode.....	13
Setting CT Primary, CT Secondary, PT Primary and PT Secondary	13
Setting Neutral CT Primary, Neutral CT Secondary, Password and Log Duration	14
Setting Real Date, Time, Baud Rate and Unit Address for RS485 Port.....	15
Selecting Relays, Alarm Parameters, Alarm Values and Hysteresis	15
Selecting Events, Event Parameters, Event Values and Hysteresis.....	16
Selecting Demand Window (both KW and KVA), Installation type and Reset Demand.....	17
Resetting Energy, Min-Max parameters, Logs and Max Demand.....	18
Resetting Event, All Parameters and Restore to Default Values.....	18
Run Mode.....	19
Run Mode display in 3P4W and 3P3W.....	19
Communication	25
Modbus RTU on RS485 Port	25
Data Logging using USB Port and Pen drive.....	25
Installing the USB Software	26
Installation of USB driver.....	27
Handling the Logger Window.....	29
Downloading the Logged data	29
Exporting the Logged Data including Min/Max Events and Harmonics Data	30
Graph Representation.....	31
Plotting a Graph for Logged data.....	31
Data Download Using a Pen Drive.	33
Programming Mode Using Utility	34
Control Outputs.....	36
Alarm Action	36
Goblin as a Load Manager / Demand Management.....	37
Appendix	38
Address Map of Various Parameters for 3P4W installation.....	38
Address Map of Various Parameters for 3P3W installation	40

Introduction

The digital power meter GOBLIN is a micro-controller based unit which not only measures a host of electrical parameters to display them on a 128 X 64 graphical backlit LCD, but also acts as a comprehensive load managing device due to its four numbers of output relay contacts. These outputs are individually field programmable for both the parameter on which to generate alarm as well as the values on which to activate alarm and deactivate it. In addition to this flexibility in terms of load management, the meter also has two serial ports: USB data downloading using USB data cable and Pen drive. In addition, RS485 supports MODBUS RTU protocol for connections to EMS/SCADA.

The unit is meant for use in three phase four wire and three phase three wire systems. The installation type, CT ratios and PT ratios are site selectable. The Load Manager with its four relay contacts can be used as a Demand Controller. The method of Demand calculation i.e. Sliding window or Fixed window can also be selected at site.

GOBLIN is a versatile meter with a robust electrical load management system and consists of all the features needed to implement. It can be configured to suit most control and communication needs.

The Main features Available in this Model

- Displays more than 20 Parameters
- Demand and Maximum Demand
- Four Relay contacts, individually field programmable, for alarm parameter as well as on/off values
- RS485 MODBUS-RTU Connectivity
- Data downloading of logged data using USB port and Pen drive
- Large 128 X 64 Backlit LC Display
- On board 2 MB of non-volatile memory and data logging with field programmable log duration
- CT / PT Ratios field programmable
- Odd Harmonic Analysis up to 15th for all voltages and currents, including THD.



Technical Specifications

Parameters			
Type	Name	Statistics	
INPUT	Three Phases and Neutral of a 3P4W system / Three Phases of a 3P3W system		
	Voltage	Direct Voltage Input : Up to 500V L-L, Up to 300V L-N PT Ratio : Site Selectable Burden : 0.5VA	
	Current	Secondary Current Input: 5A or 1A (Site Selectable) CT Ratio : Site Selectable Range of Reading : 5 – 5000A Burden : < 1.0VA Overload : 5A CT = 6A RMS Continuous 1A CT = 1.2A RMS Continuous	
	Power Supply	Auxiliary Supply: 80 - 470 VAC, 50-60 Hz.	
OUTPUT	Relay	Four. Individually Field Programmable. Switching Voltage : Max. 230 VAC Switching Power : Max. 1000W Expected Mechanical Life : >10X10 ⁶ switching operations Expected Electrical Life : > 4X10 ⁶ switching operations @ (Load = 200VA. Cosφ = 0.5)	
MEASUREMENT	True RMS Basic Parameters	Voltage (Volts L-N & L-L)	VL-N Accuracy : 0.5% of Reading VL-L Accuracy : 1.0% of Reading
		Current (Amps IR, IY, IB)	Accuracy : 0.25% of Reading
		Line Frequency	45 to 55 Hz, Accuracy : 0.3% of Reading
	Power	Active Power (P)	Accuracy : 1% of Reading (For IPFI>0.5)
		Reactive Power (Q)	Accuracy : 1.5% of Reading (Between 0.5 Lag to 0.8 Lead)
		Apparent Power (S)	Accuracy : 1% of Reading
		Power Factor	For Individual phases and System. Accuracy : 1.0% of Reading (IPFI≥0.5) Range of Reading : 0.05 to 1.00 Lag/Lead
	Energy	Total Active Energy (KWh)	Range of Reading : 0 to 99999999.9 KWh Accuracy : 1.0S as per IS13779.
		Total Apparent Energy (KVAh)	Range of Reading : 0 to 99999999.9 KWh Accuracy : 1.0% of Reading
		Total Apparent Energy (KVARh)	Range of Reading : 0 to 99999999.9 KWh Accuracy : 1.5% of Reading
	Power Quality	3 rd to 15 th Harmonics(Odd) for all Voltages with THD	
		3 rd to 15 th Harmonics(Odd) for all Currents with THD	
	Demand	Active Power (KW) Demand - Sliding & Fixed Selectable	
		Apparent Power (KVA) Demand - Sliding & Fixed Selectable	

MISCELLANEOUS

Parameters		
Type	Name	Statistics
Dimensions	Bezel	144 X 144 mm
	Panel Cutout	138 X 138 mm
	Depth of installation	55 mm
	Display	128 X 64 graphical Backlit LCD
	Operating temp	10°C to 50°C
	Weight	0.65 Kgs (Approx.)
	Operating Current Range	0.4% to 120% of CT primary
Communication	Data Logging Buffer	2 MB, Non-volatile memory, Can hold 19691 records
	Logging Duration	Site selectable from 1 minute to 60 minutes
	RS485	Modbus-RTU protocol
	USB	For downloading logged data
	Pen Drive	

Installation and Commissioning

The Goblin supports two installation modes – 3P4W and 3P3W. The installation process of these modes is described below:

3P4W Mode Installation

Follow these steps to install / commission the unit.

1. Push the unit into the panel and mount using the clamps provided. Connect the Auxiliary supply to the terminals marked P and N. The Auxiliary supply range is 80 V AC to 270 V AC.

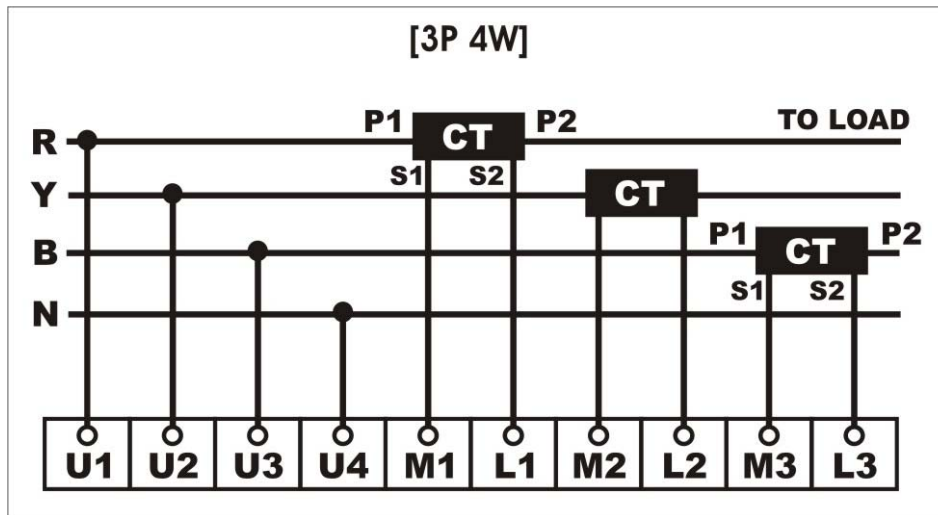

2. Connect the three phases with the phase sequence being R-Y-B to the terminals marked U1, U2 and U3 respectively. Make sure that the three phases coming to the unit come through control fuses of 1.0 Amp rating. This will protect the electronics inside from damage due to severe overvoltage or phase faults in the system.
3. Connect the neutral to the terminal marked U4.
4. Connect the two wires from the R-phase CT to terminals marked M1 & L1 such that S1 from CT goes to M1 on the unit. Connect the two wires from the Y-phase CT to terminals marked M2 & L2 such that S1 from CT goes to M2 on the unit. Connect the two wires from the B-phase CT to terminals marked M3 & L3 such that S1 from CT goes to M3 on the unit.
5. Switch on the three phase supply as well as Auxiliary supply. The unit will come alive and display power information such as factory location for about three seconds and then, it will display the first page of Run Mode.
6. If there is very little current or no current in the CT circuits, the unit may show PFs as 0.999 or 1.000. This will go away as soon as the current builds up in the CTs, above 0.4 % of rated CT.

7. Now, the unit needs to be programmed for the various parameters which are field programmable. For this refer to next section “OPERATIONAL DETAILS”
8. The unit is ready for operation.

3P3W Mode Installation

Follow these steps to install / commission the unit.

1. Push the unit into the panel and mount using the clamps provided. Connect the Auxiliary supply to the terminals marked P and N. The Auxiliary supply range is 80 VAC to 270 VAC.

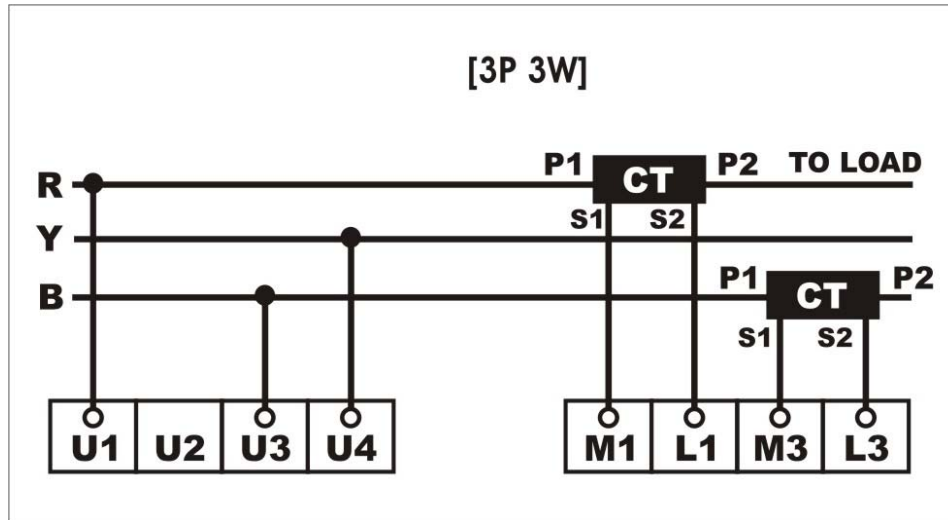

2. Connect the three phases with the R phase to the terminal U1, B phase to terminal U3 and Y phase to terminal U4. Make sure that the three phases coming to the unit come through control fuses of 1.0 amp rating. This will protect the electronics inside from damage due to severe overvoltages or phase faults in the system.
3. Connect the two wires from the R-phase CT to terminals marked M1 & L1 such that S1 from CT goes to M1 on the unit. Connect the two wires from the B-phase CT to terminals marked M3 & L3 such that S1 from CT goes to M3 on the unit.
4. Switch on the three phase supply. The unit will come alive and display power receiving information such as factory location for about three seconds and then, it will display the first page of Run Mode.
5. If there is very little current or no current in the CT circuits, the unit may show PFs as 0.999 or 1.000. This will go away as soon as the current builds up in the CTs, above 0.4 % of rated CT.
6. Now, the unit needs to be programmed for the various parameters which are field programmable. For this refer to next section "OPERATIONAL DETAILS".
7. The unit is ready for operation.

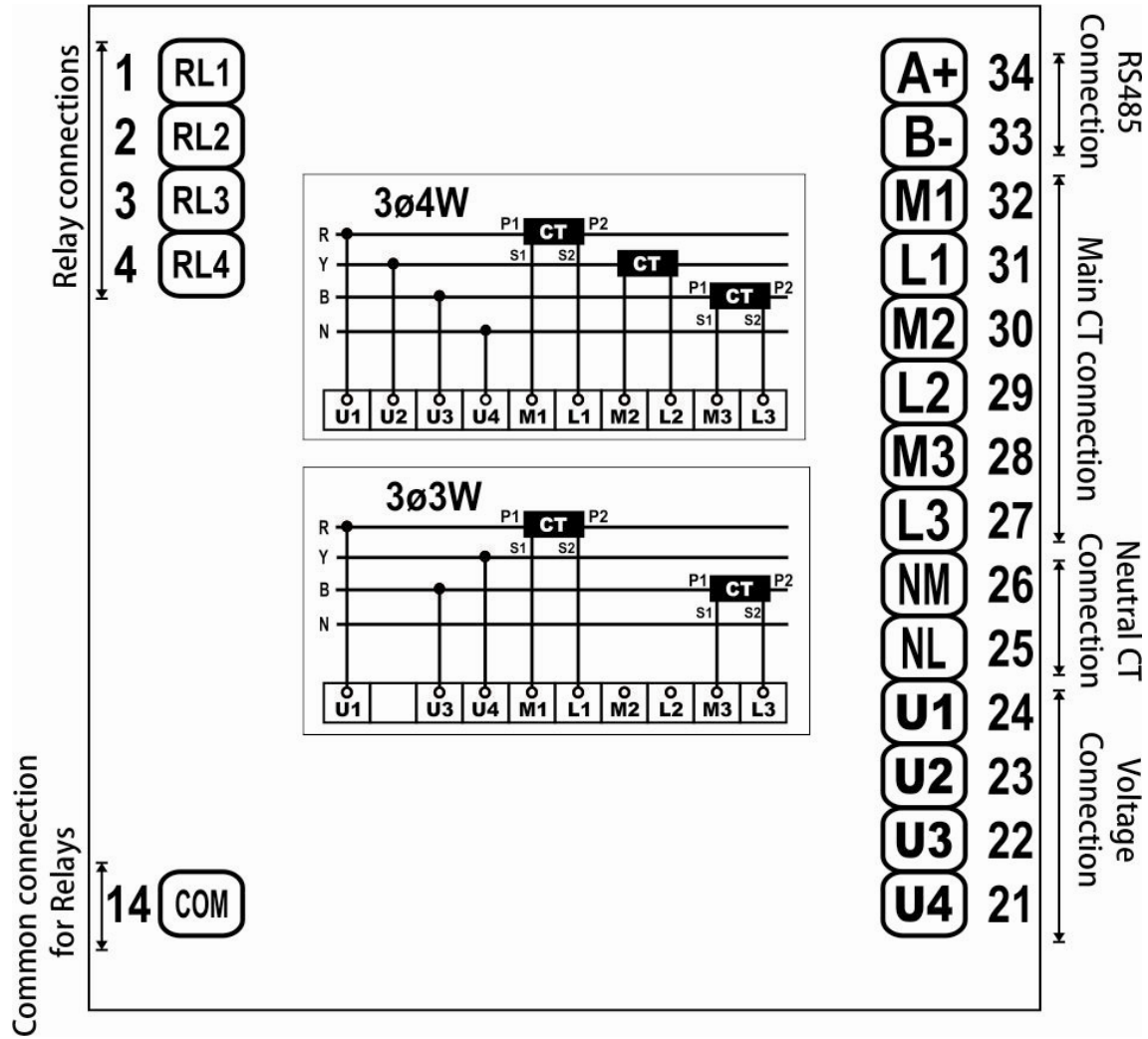

Connection Scheme

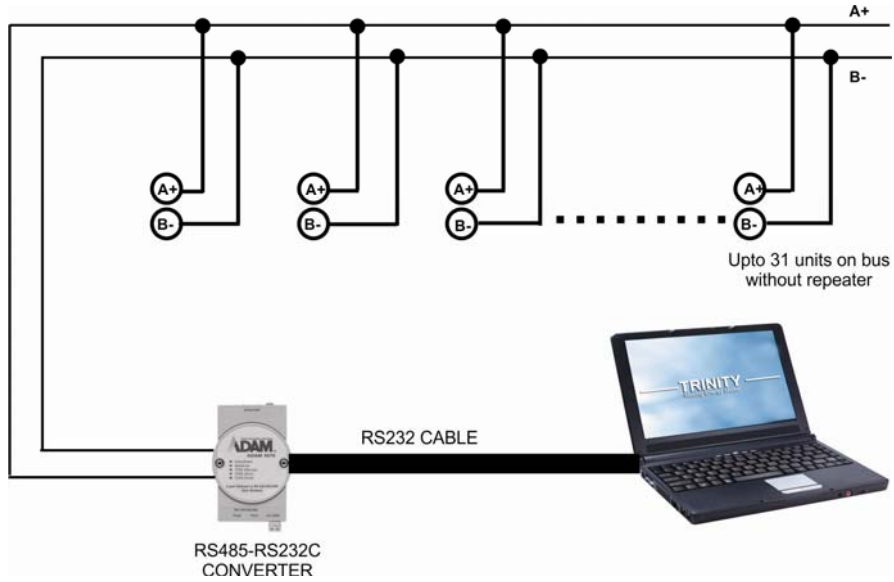

RS485 Connection

Operational Details

The load manager, GOBLIN is a versatile meter, with all the features needed to implement with a robust electrical load management system. It can be configured to suit most control and communication needs.

This is achieved by making as many parameters field programmable, as much possible. The unit can be operated with three modes such as:

1. Programming Mode
2. Programming Mode Using Utility
3. Run Mode

For Programming Mode Using Utility, refer in latter section, “Communication”.

After supplying power (80 VAC - 470 VAC) to the three phases along with auxiliary supply the unit displays immediately power receiving information such as Factory name and Location and then, enters into first page of Run Mode such as shown below.

Vry=521. 5
Vyb=521. 1
Vbr=521. 7
Frq. =49. 80









Now, the unit can be operated by pressing keys provided with the following:



Programming Mode

The unit is designed with a secure default password, "1947". The password is also changeable from 0 to 9 according to user's desire (see in the next section, programmable parameter, "Changing a Password"). To enter into Programming Mode, press  in Run Mode for about four seconds and then, the password display will show with a four digits of zeroes of which first digit, zero will be blinking.

PASSWORD
0000

To enter the password, press  key one time which will alter into first digit, 1 and press  key to shift into second digit. Press  again nine times to alter into 9, press  key again to shift into 3rd digit and press  key four times to alter into 4 and then, press  key to shift into 4th digits and press  key seven times to alter into 7. After entering the default password, press  key to enter into Programming Mode. 'P' shows blinking in each page which indicates the page is in Programming Mode.

Setting CT Primary, CT Secondary, PT Primary and PT Secondary

In order to give actual currents and voltages, the CT Primary, CT Secondary, PT Primary and PT Secondary should be selected with the following:











- CT Primary:- freely programmable from 5 to 5000.
- CT Secondary:-selectable to either 1 or 5.
- PT Primary: 3.3 KV, 6.6 KV, 11KV, 22KV, 33KV, 66KV, 110V, 415V, 440V.
- PT Secondary: 110V or 415V and 440V.

To set the above parameters, proceed the following instructions.

1. After entering the password such as steps before, the unit enters into Programming Mode and shows an arrow onto CT-Primary by default with the following page.

```
>CT PRI: 500  
CT SEC: 5  
PT PRI: 415V  
PT SEC: 415V P
```

2. Press  key which will start blinking the Arrow and the parameter can now be

- set by pressing  and  keys. Set the desired parameters and then, press  key to confirm the setting that will also stop blinking.
3. Press  key to enter into the next parameter, CT Secondary and press  key again which will start blinking the Arrow along with the parameter. Select the desired CT Secondary by pressing  and  keys as steps before and press  key again to confirm.
 4. Set PT Primary, PT Secondary also with the same steps before.
 5. If the setting is completed, press  for about four seconds to return into Run Mode. Otherwise, press  key to set for next parameters such as before.

Setting Neutral CT Primary, Neutral CT Secondary, Password and Log Duration







In the above Programming Mode, press  key till the unit enters into the following display and then, set such as steps before.

```
>N_CT PRI: 1280
  N_CT SEC: 1
  CHG PASWRD: 0000
  LOG DUR: 1 Min   F
```

Neutral CT Primary and Secondary

Neutral CT Primary is settable from 5 to 5000 and CT Secondary is selectable to either 1 or 5. To measure actual Neutral current, both Neutral CT Primary (N_CT PRI) and CT Secondary (N_CT SEC) should be set.

Changing a Password

Password (CHG PASWRD) is changeable from 0 to 9. To change the password, press  key to enter the Arrow onto PASSWORD and then, press  keys that will start blinking with first digit, "0" which shows the password can be changed. Set any digits from 0 to 9 by pressing  key and press  key to shift into next digits and set four digits with the same steps. In case, any set digit is necessary to change again, press  key till the desired digit is blinking and then set as before steps. After setting the four digits, press  again to confirm it.

Log Duration







For logging the parameters, the Log Duration (LOG DUR) can be specified from 1 to 60 minutes. GOBLIN has the capability to log data on its own Non-volatile RAM. This data is logged in an FIFO buffer. Once the buffer (19691 records) is full, the oldest data is discarded and the newest data is filled into the buffer. This data can then be downloaded by using a software utility provided by Trinity, to a PC, record by record.

Setting Real Date, Time, Baud Rate and Unit Address for RS485 Port

In the above Programming Mode, press  key till the unit enters into the following display and then, set such as steps before.

```
>DATE: 28/02/2011
  TIME: 13: 38: 24
  BAUD RATE: 9600
  ADDRESS: 3      P
```

Real Date and Time (RTC)

The Real Date can be set with the format of date, month and year (i.e. DD/MM/YYYY). To set the Date, press  key that will start blinking both “DD” and Arrow. Set ‘DD’ by pressing  and  keys and then, press  key to shift onto month (MM) and set by pressing  and  keys as steps before. Likewise, set years YYYY also.

The Real Time can also be as above steps with current time where the Time shows with the format of hour, Minute and Second (i.e., HH/MM/SS). Here the Hour should be set as 24 hour. This real time will also reflect into data logging which can be observed after downloading logged data.

Baud Rate and Unit Address for RS485 Communication port.

In case of RS485 port, the BAUD RATE is settable to either 9600 or 19200 and the unit Address is settable from 1 to 255.

Selecting Relays, Alarm Parameters, Alarm Values and Hysteresis

In the above Programming Mode, press  key till the unit enters into the following display and then, set such as steps before.

```
>RELAY: 1
  ALARM ON: KVAR
  ALARM VAL: 1
  R_HYSTER.: 1      P
```

Relay (rly)

GOBLIN has four relay contacts, which are individually field programmable from 1 to 4.

Alarm on

There are seven alarm parameters: Avg. Volts $[(Vry+Vyb+Vbr)/3]$, Avg. Amps $[(Ir+Iy+Ib)/3]$, KVA, KW, KVAR, KW Demand, KVA Demand and PF. These

parameters are programmable for each alarm relay according to user's requirement. In case, user is not desired for alarm, the Alarm should be set to NONE.

Alarm Value

Alarm values are freely programmable from 1 to 10000. In case of Avg. Volts, the parameter is freely programmable from 1 to 70000. The value indicates the level at which the relay will close. e.g., If the ALARM ON has been selected to KW, and ALARM VALUE is set to 450, the relay will close when the KW exceeds 450 and remains so for 1 minute.

Also, the switching ON logic for PF is reversed. For all parameters, the relay closed when the parameter value **exceeds** that defined by Value for more than one minute. In case of PF however, the relay will close when the PF **falls** below the Value and remains so for more than one minute. Also, the PF Value should also be read with a multiplication factor of 1000. e.g. If the Alarm parameter, PF is set with its value, 955, the relay will close when PF falls below 955(0.955 PF X1000 =955).

Hysteresis

The last parameter called Hysteresis that defines the opening point for the relay which has closed in response to an alarm condition. This is specified as percentage of the Value. Thus, setting Hysteresis of 2 implies that the relay which closes when the parameter reaches the setting Value and opens when the parameter falls below 0.98 x Value. This implement comes to prevent frequent operation / nuisance operation of the relay near the setting Value.

Selecting Events, Event Parameters, Event Values and Hysteresis

In the above Programming Mode, press  key till the unit enters into the following display and then, set such as steps before.

```
>EVENT: 1
  EVENT ON: I avg.
  EVENT VAL: 450
  E_HYSTER.: 2      P
```

Event

There are four types of Event which can be logged for user defined event parameters.

Event On

There are seven event parameters: Avg. Volts $[(V_{ry}+V_{yb}+V_{br})/3]$, Avg. Amps $[(I_r+I_y+I_b)/3]$, KVA, KW, KVAR, KW Demand, KVA Demand and PF. These parameters are programmable for each event according to user's desire. In case, user is not desired any event, the event should be set to NONE.

Event Value

Alarm values are freely programmable from 1 to 10000. In case of Avg. Volt, the parameter is freely programmable from 1 to 70000. The value indicates the level at

which the event will log. E.g. If the EVENT ON for EVENT 1 has been selected to KW, and the value is set to 450, the EVENT 1 will log when the KW exceeds 450 and remains so for 1 minute.

In case of PF, the PF value is entered with a multiplication factor of 1000. e.g. PF, 955 should be read as 0.955 with a multiplication factor of 1000. EVENT will thus log when the PF **falls** below 0.955 and remains so for more than one minute.

Event Hysteresis

The Event Hysteresis is also same as Alarm Hysteresis defined before.

Selecting Demand Window (both KW and KVA), Installation type and Reset Demand

In the above Programming Mode, press  key till the unit enters into the following display and then, set such as steps before.

```
DMN ON: KW & KVA
>DMD WIND: SLI_30
INST. : 3P4W
RST DMD: MAN.      F
```

Demand On

Demand Window specifies for both two Demands: KW and KVA and so the Demand ON, KW & KVA are fixed that is not settable. For both the Demand Window, Sliding and Fix Demand are an integration period of 30 or 15 minutes. The demand calculation is selectable to Fix Demand or Sliding Demand with the following: FIX-15, FIX-30, SLI-15 and SLI-30.

Installation type

The unit supports two types of Electrical installation such as 3P4W and 3P3W. According to your electrical installation, the installation type should be selected to either 3P4W or 3P3W as before setting.

Reset Demand

Reset Demand can be specified such as whether the demand will be reset automatically or manually. In case of automatic reset, there are two options: auto_day or auto_month. If user selects auto_day then DEMAND will reset every 24 hrs at 12:00 a.m. and if user selects auto_month then DEMAND will reset on 1st of every month at 7:00 a.m. Otherwise, RESET DEMAND should be set to MAN., to reset manually.

Resetting Energy, Min-Max parameters, Logs and Max Demand

In the above Programming Mode, press  key till the unit enters into the following display and then, set such as steps before.

```
>RESET ENERG: NO
RST MIN-MAX: NO
RESET LOGS: NO
RST MAXDMD: NO    P
```

Reset Energy

The Energy counter can be reset for all three energies recorded. This feature can be used judiciously, as resetting Energy counters reflect in the logged data also and can cause errors in the reports generated.

Reset Minimum and Maximum

The minimum and maximum value for all the parameters can be reset to zero.

Reset Log

The logged data for all the parameters can be reset to zero.

Reset Maximum Demand

The Maximum Demand for both KW and KVA recorded can be reset to zero.

Resetting Event, All Parameters and Restore to Default Values

In the above Programming Mode, press  key till the unit enters into the following display and then, set such as steps before.

```
>RST EVNT: NO
RESET ALL: NO
RESTOR DEF. : NO
                P
```

Reset Event

The Event logging for all the event parameters can be reset to zeroes.

Reset All

All the reset parameters mentioned above can be reset to zeroes.

Restore Default parameter

The unit has a feature of which user can restore for all counters to a default values in Programming Mode.

Once reset, the user has to re-programme all parameters again.

Run Mode

In the run mode, the various parameters measured/calculated by the meter are displayed on different pages on a 128X64 graphical Backlit LC Display.

Run Mode display in 3P4W and 3P3W

```
Vry=408.5  
Vyb=413.1  
Vbr=415.7  
Frq. =49.80
```

The first page shows phase to phase voltage of three phases (i.e., Vry, Vyb and Vbr) in first line, second line and third line respectively. The last line shows Frequency (Hz).

```
Ir=29.18  
Iy=29.24  
Ib=32.21  
In=1.2
```

The second page shows currents in R-phase, Y-phase and B-phase (i.e., Ir, Iy and Ib) in first line, second line and third line respectively. The last line, 'In' shows neutral current (Neutral current is not displayed in 3P3W).

```
Vrn=238.6  
Vyn=235.7  
Vbn=240.8
```

The third page shows phase to neutral voltage in three phases (i.e., Vrn, Vyn, Vbn) in first line, second line and third line respectively.

PF:
R=0. 797 LG
Y=0. 784 LG
B=0. 813 LG

The fourth page shows PF in three phases (i.e., R-phase, Y-phase and B-phase) in second line, third line and fourth line respectively.

KW=17. 27
KVA=21. 61
KVAR=13. 07
PF=0. 796 LG

The fifth page shows Active Power (KW), Apparent Power (KVA) and Reactive power (KVAR) in first line, second line and third line respectively. The last line shows System PF with PF lagging.

KVAh=
8. 09
KWh=
5. 99

The sixth page shows Apparent Energy (KVAh) and Active Energy (KWh).

KVARh (LD) =
5. 56
KVARh (LG) =
4. 10

The seventh page shows Reactive Energy in LEAD and LAG.

```
KW DM=456
KW MD=751
Dt=02/11/00
Tm=21: 19: 25
```

The eighth page shows the KW present Demand (DM) along with the Maximum Demand (MD) reached. There are a few points regarding Demand and maximum demand display, which need to be noted.

- The demand is integrated over 30 minutes or 15 minutes in both FIX and SLIDING WINDOW.
- If the demand is calculated by the meter, based on sliding window technique, then unlike utility installed demand meters, this demand figure does not reset to zero at the end of the 15 minutes or 30 minutes integration window.

```
LMD KW=400
Dt=21/01/11
Tm=11. 45. 17
```

The ninth page indicates the date and time of last KW maximum demand (LMD) occurrence and status of the logging buffer. This value holds for the user the value of maximum demand (MD) as it was, before it was reset. For example let present maximum demand be 400 KW. Now if the user reset MD then MD will become zero and LMD will hold the value 400KW.

```
KVA DM=440
KVA MD=451
Dt=02/11/00
Tm=21: 19: 25
```

The tenth page shows the KVA present Demand (DM) along with the Maximum Demand (MD) reached. There are a few points regarding Demand and maximum demand display, which need to be noted.

- The demand is integrated over 30 minutes or 15 minutes in both FIX and SLIDING WINDOW.

- If the demand is calculated by the meter, based on sliding window technique, then unlike utility installed demand meters, this demand figure does not reset to zero at the end of the 15 minutes or 30 minutes integration window.
-

LMD KVA=445
Dt=01/02/11
Tm=12: 22: 12

The eleventh page indicates the date and time of last KVA maximum demand (LMD) occurrence. This value holds for the user the value of maximum demand (MD) as it was, before it was reset. For example let present maximum demand be 445 KVA. Now if the user reset MD then MD will become zero and LMD will hold the value 445KVA.

Vr	Hr _m [%]	9TH	0.9
3rd	2.1	11th	0.9
5th	1.2	13th	0.8
7th	0.5	15th	0.4

The twelfth to fourteenth page show Odd Harmonics voltage of R-Phase, Y-Phase and B-Phase, 15th to 17th page show Odd Harmonics current of R-phase, Y-Phase and B-Phase with the same display. However, the harmonics data will be different accordingly.

The meter measures and displays the Harmonic contents of all the voltage and current waveforms. This data is normalized against the strength of the fundamental frequency. In other words, the fundamental is always at 100%, and the strength of the higher harmonics are expressed as the percentage (%) of the fundamental. The highest order of the Harmonics displayed is 15th. Thus, the meter shows third, fifth, seventh, ninth, eleventh, thirteenth and fifteenth harmonics, for each voltage and current.

The method of calculating the Harmonics is by taking samples and subjecting those to Digital Signal Processing technique of Fast Fourier Transform. The data is averaged and updated once every six seconds.

The current channels need to have a minimum current of 3.2 % of the rated CT secondary, for FFT to be run on the samples. If the current is less than this limit,

the Harmonic data page for that current will show 0.0 % for all values.
 The Harmonic data is also available over the serial communication link, RS 485, Modbus protocol.

In case of 3P3W installations, the Harmonic data of Y phase is not applicable.

THD [%]			
Vr	2.1	Ir	0.0
Vy	1.2	Iy	0.8
Vb	0.5	Ib	0.4

The eighteenth page shows Total Harmonics Distortion based on its waveform in percentage for individual voltage and current in three phases.

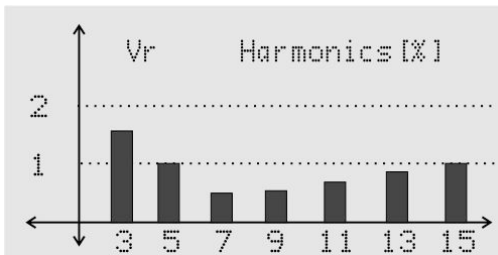

The 19th, 21st and 23rd pages show the histogram form of Odd Harmonics voltage upto 15th in percentage for R-phase, Y-Phase and B-Phase respectively.

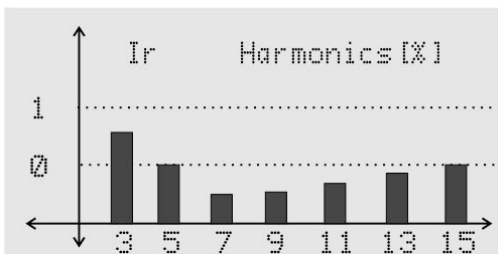

The 20th, 22nd and 24th pages show the histogram form of odd harmonics current upto 15th in percentage for R-phase, Y-Phase and B-Phase.

31/02/2011
 13: 31: 26
 LOGS=19691
 Overflow=NO

The twenty-fifth page shows date and time of data logging for all parameters. The maximum LOGS is upto 19691. Once the LOGS is overflow, LOGS will start from 1 and OVERFLOW will show YES. This Log can be seen after downloading the data by using USB data or pen drive.

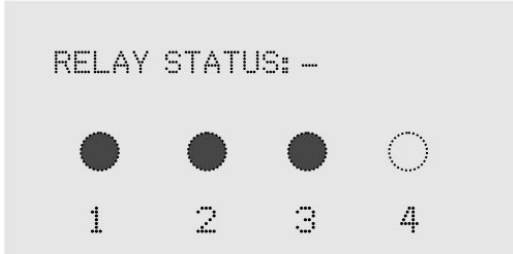

The twenty-sixth page shows relays status. The solid circle from 1 to 3 show the relays defined for Alarm/trip action whereas, the relay 4 which shows as an empty circle, is off.

Communication

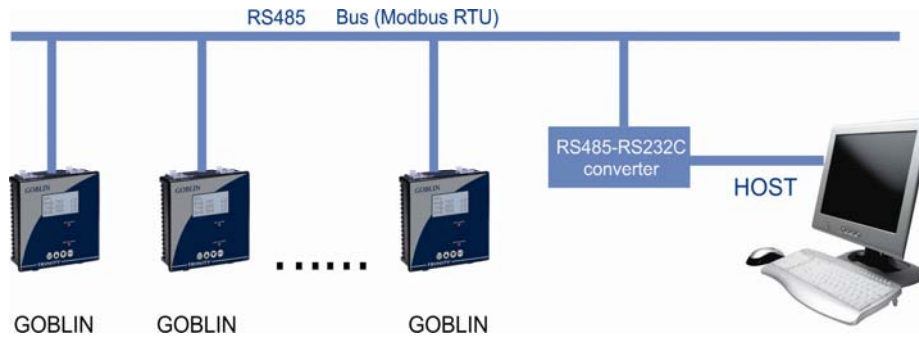

In addition to the industry standard RS-485 communication port, other communication options: USB 2.0 and pen drive for downloading of logged data are also available in **Goblin**. These options make it possible for a user to select Goblin to provide power and energy information into a variety of existing or new control systems. Each communication option supports data transfer with external devices or applications. Metering measurement, logged data, configuration and status data may be accessed via communication.

Modbus RTU on RS485 Port

For connection to a SCADA software, Goblin supports an RS485 port with MODBUS-RTU protocol. The station id for every meter is site selectable, and so is the baud rate. The data which can be read using MODBUS query # 3 (Read Holding Registers) is provided in an address map, with the applicable multiplication factors, vide **Appendix A**.

Communication line parameters: 9600 or 19200/8/N/1.

The register map is described in Appendix A. All addresses are in decimal whose parameters are unsigned long. If illegal address is sent in query or the host, tries to read more than 64 bytes of data in one query exception message is generated.

Reserved values are for future use, which are transmitted as zeroes.

Data Logging using USB Port and Pen drive

Goblin has a 2 MB non-volatile memory. This memory is used to store the minimum and maximum values of important parameters, events as defined by the user and the snapshot of the entire electrical system where all instantaneous and integrated parameters along with Harmonic data are saved. Maximum numbers of such electrical snapshots are 19691.

While the electrical snapshots as saved in the logs can give a good idea of the overall behavior of the system, the Event Log feature captures time-stamped records of important power system occurrences that can be aligned with corresponding

production effects to better understand and optimize energy use and cost.

One can monitor values over a day, a week, a month or any period to record the highest and lowest values of voltage, current, power factor including Event parameters.

Goblin supports USB 2.0 and Pen Drive for downloading of logged data. For USB, users are provided a CD for USB utility installation along with the purchase of Goblin. Before installing the software, users are advised to read carefully **Read Me** document in Logger disc for a list of minimum system requirements to be installed, if uninstalled before. If your system does not meet the minimum system requirements, installation of Goblin software will not be possible.

Installing the USB Software

1. Insert the **Logger** setup CD into the CD-ROM drive of your computer after windows is started.
2. Double click on the **Logger** and select **Logger Setup** or **Setup** and then, double click on any of the setup. Wizard welcomes for Logger Setup. To proceed the installation, click **Next** and then, the wizard will show the following dialog box for the location.

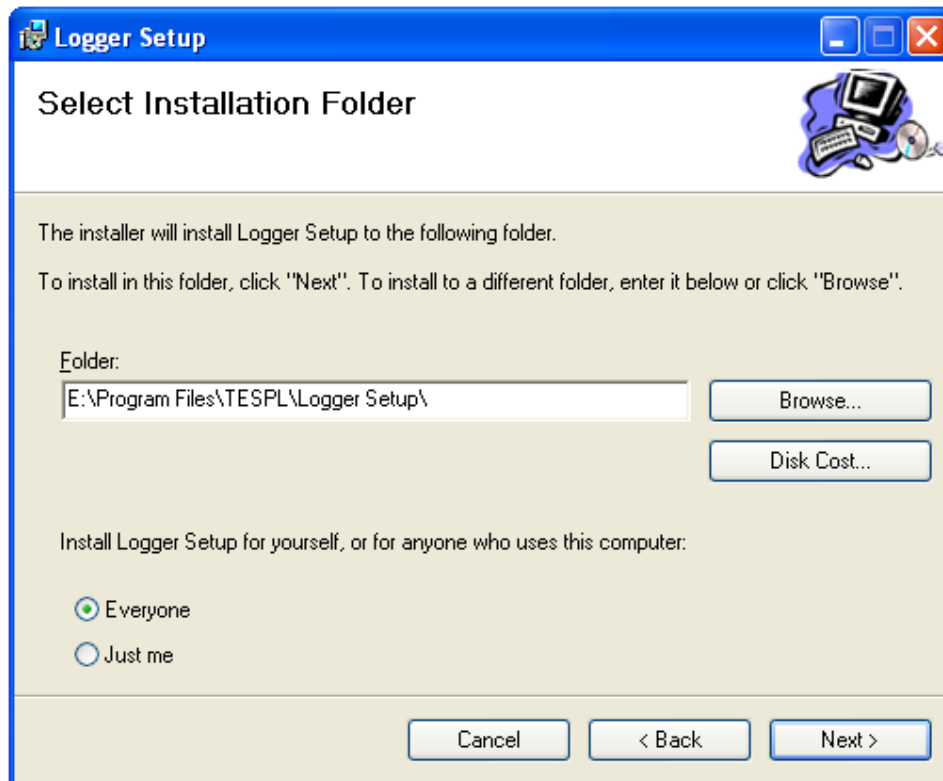

3. Before selecting the location, user can also check the disk space for each drive clicking **Disk Cost**. The Logger Setup has also two options such as **Everyone**

and **Just me** of which Everyone is selected by default.

4. To confirm the installation, click **Next** in the next wizard and wait for some time while proceeding the installation. After completing the installation, the wizard will display the Logger Setup has been installed successfully. Now click **Close** to exit the wizard.

Installation of USB driver

Make sure that the USB cable is connected in between the PC and unit. If the USB connection is not all right, remove the USB cable and connect again. If the USB is connected for the first time, the wizard will show with following option.



Select the option, **Yes, This time only** and click **Next** to proceed for the next wizard such as shown below.

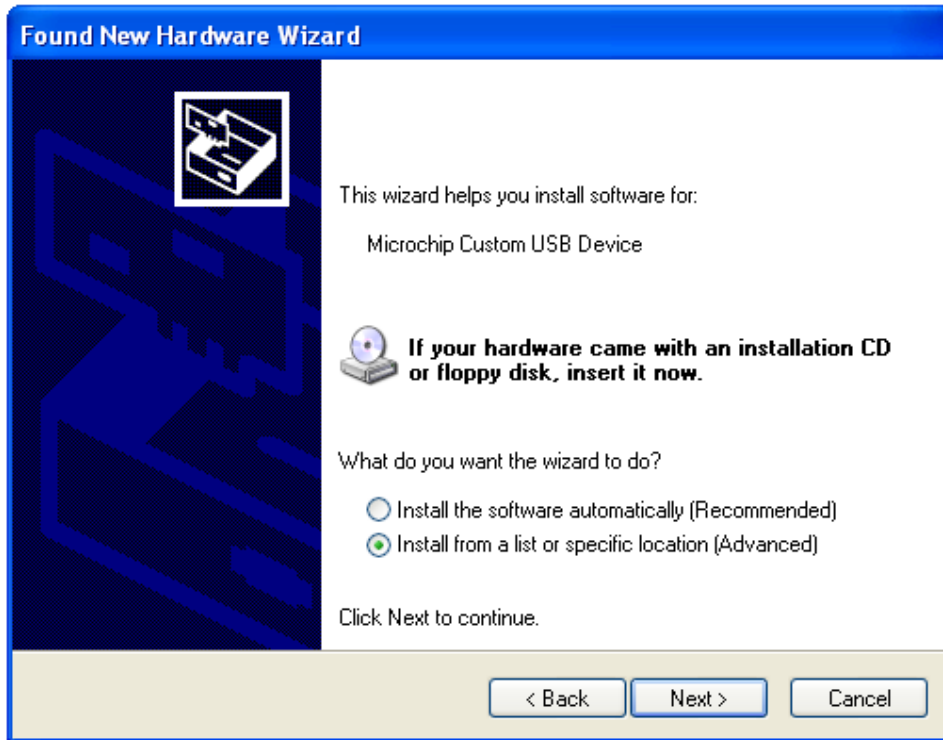

The wizard will ask if your hardware comes with an installation CD or floppy disk, insert it now. Select the wizard option, **Installation from a list or specific location** and click **Next** to give the following dialog box where the file is located.

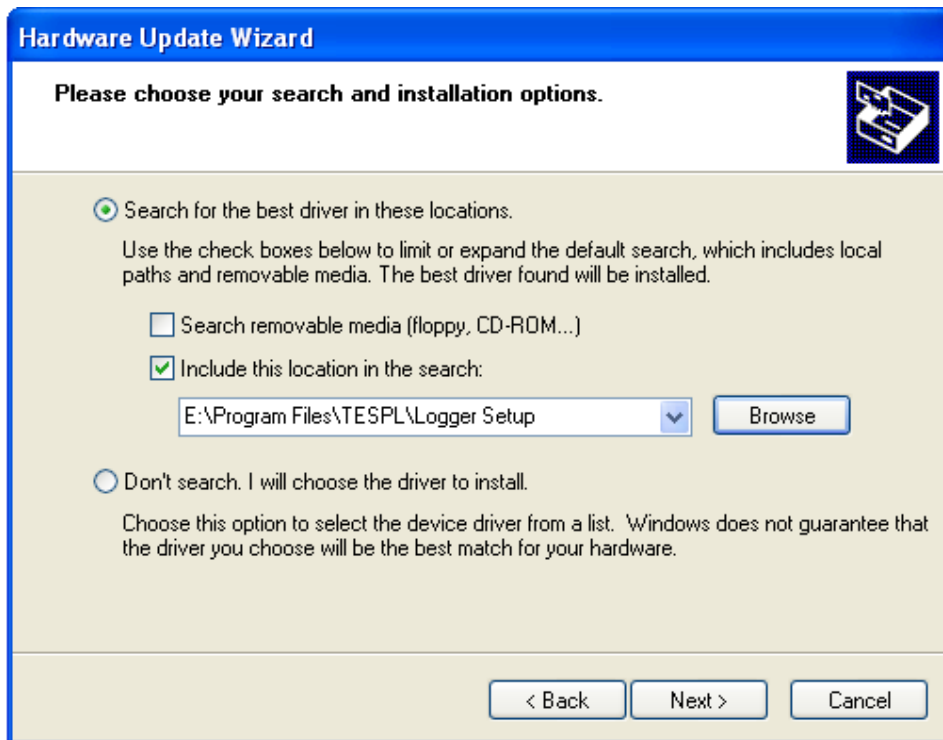

In the above dialog box, select option **Search for the best drive in these**

location and click check box of **Include this location in the search** to specify path of usb drivers and then, click **Next** to get the path where the file is located.

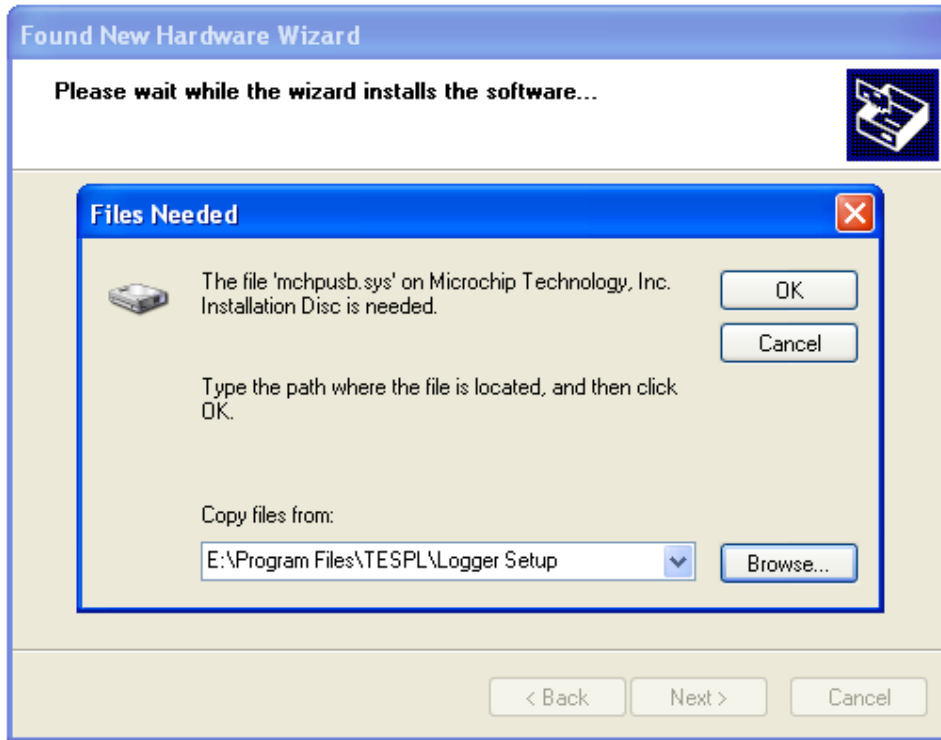

5. Now click **OK**, to complete the wizard.
6. Wait for sometimes while completing the wizard and then the wizard will prompt the new hardware gets completed. Now click **Finish** to complete the installation.

Handling the Logger Window

The Logger window consists of the following: Downloading logged data, harmonic data, Graph representation onto Logger window and Exporting the Logged data in to a excel sheet.

Downloading the Logged data

1. By default the utility will show **Logger** (including version numbers) on desktop. Double-click on the **Logger** icon. Now the Logger will open with the following window.

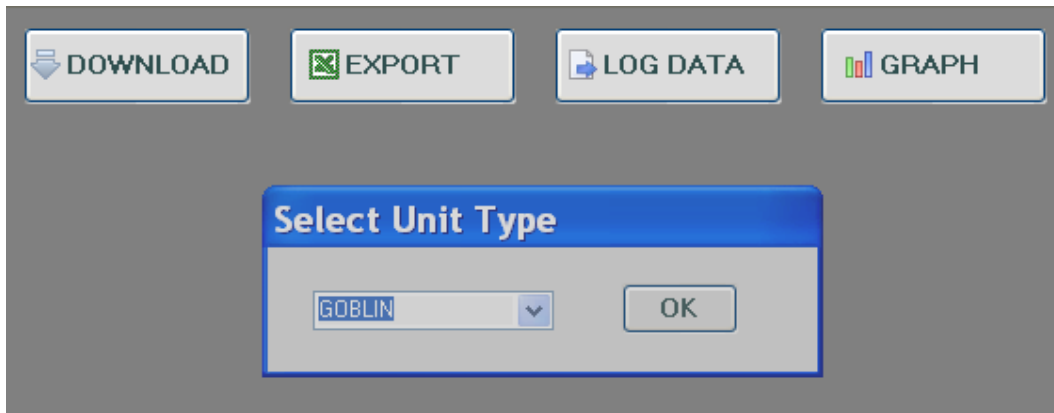

- In the unit type list, select the Goblin and click **OK** and to start downloading, click **DOWNLOAD** and then, the logged data will open with the following logger window.

No.	Date	Time	Vm	Vyn	Vbn	Ir	Iy	Ib	I-Neutral	Vry	Vyb	Vbr	Sys-PF	KW	KVA	KVAR	Hz	KWh	KVAh	KVARh
1	05/03/10	11:50:07	231.9	231.3	232.9	397.0	167.7	126.6	126.6	401.1	401.9	402.4	0.895	143.5	160.4	71.7	50.00	572.0	653.5	316.1
2	05/03/10	11:50:17	231.9	231.3	232.8	396.8	167.7	126.6	126.6	401.1	401.9	402.4	0.895	143.5	160.4	71.7	50.00	572.4	654.0	316.3
3	05/03/10	11:50:27	231.9	231.4	232.8	396.9	167.7	126.6	126.6	401.2	402.0	402.4	0.895	143.5	160.4	71.7	50.00	572.8	654.4	316.5
4	05/03/10	11:50:37	231.9	231.4	232.8	396.7	167.7	126.6	126.6	401.2	402.0	402.4	0.894	143.5	160.5	71.8	50.00	573.2	654.9	316.7
5	05/03/10	11:50:47	231.9	231.4	232.8	396.4	167.9	126.6	126.6	401.2	402.0	402.4	0.894	143.4	160.4	71.8	50.00	573.6	655.3	316.9
6	05/03/10	11:50:57	231.9	231.3	232.8	396.3	167.8	126.6	126.6	401.1	401.9	402.4	0.894	143.4	160.4	71.8	50.00	574.0	655.8	317.1
7	05/03/10	11:51:07	231.9	231.4	232.8	396.1	167.9	126.6	126.6	401.2	402.0	402.4	0.894	143.4	160.3	71.7	50.00	574.4	656.2	317.3
8	05/03/10	11:51:17	231.9	231.4	232.8	396.0	167.9	126.6	126.6	401.2	402.0	402.4	0.895	143.3	160.2	71.8	50.00	574.8	656.7	317.5
9	05/03/10	11:51:27	231.9	231.4	232.8	395.7	167.9	126.6	126.6	401.2	402.0	402.4	0.895	143.3	160.2	71.6	50.00	575.2	657.1	317.7
10	05/03/10	11:51:37	231.9	231.3	232.8	395.7	167.9	126.6	126.6	401.1	401.9	402.4	0.895	143.3	160.2	71.6	50.00	575.6	657.6	317.9
11	05/03/10	11:51:47	231.9	231.4	232.8	396.0	168.0	126.6	126.6	401.2	402.0	402.4	0.894	143.4	160.3	71.7	50.00	576.0	658.0	318.1
12	05/03/10	11:51:57	231.9	231.4	232.8	395.7	167.9	126.6	126.6	401.2	402.0	402.4	0.894	143.3	160.2	71.7	50.00	576.4	658.4	318.3
13	05/03/10	11:52:07	231.4	231.0	232.2	395.2	168.0	126.6	126.6	400.4	401.1	401.5	0.895	142.9	159.7	71.4	50.00	576.7	658.7	318.3
14	05/03/10	11:52:17	231.6	231.1	232.4	395.7	168.5	126.7	126.6	400.7	401.4	401.8	0.894	143.2	160.1	71.7	50.00	577.1	659.2	318.5
15	05/03/10	11:52:27	231.8	231.2	232.6	395.6	168.5	126.6	126.6	401.0	401.7	402.2	0.894	143.3	160.2	71.7	50.00	577.5	659.6	318.7
16	05/03/10	11:52:47	231.9	231.3	232.7	395.4	168.5	126.6	126.6	401.1	401.8	402.3	0.894	143.3	160.2	71.7	50.00	577.9	660.0	318.9
17	05/03/10	11:52:57	232.0	231.4	232.8	395.6	168.6	126.6	126.6	401.3	402.0	402.5	0.895	143.5	160.4	71.7	50.00	578.3	660.5	319.1
18	05/03/10	11:53:07	231.8	231.4	232.8	395.5	168.6	126.6	126.6	401.2	402.0	402.4	0.895	143.4	160.3	71.6	50.00	578.7	660.9	319.3
19	05/03/10	11:53:17	232.0	231.4	232.8	395.6	168.6	126.5	126.5	401.3	402.0	402.5	0.894	143.4	160.3	71.7	50.00	579.1	661.4	319.5
20	05/03/10	11:53:27	231.9	231.3	232.8	395.4	168.6	126.5	126.5	401.1	401.9	402.4	0.894	143.4	160.3	71.7	50.00	579.5	661.8	319.7
21	05/03/10	11:53:37	231.9	231.4	232.8	395.2	168.6	126.5	126.5	401.2	402.1	402.5	0.894	143.3	160.2	71.7	50.00	579.9	662.2	319.9
22	05/03/10	11:53:47	231.9	231.4	232.9	396.0	168.6	126.6	126.5	401.2	402.1	402.5	0.894	143.5	160.5	71.8	50.00	580.3	662.7	320.1
23	05/03/10	11:53:57	232.0	231.4	232.8	396.2	168.7	126.5	126.5	401.3	402.0	402.5	0.894	143.6	160.5	71.8	50.00	580.7	663.2	320.3
24	05/03/10	11:54:07	231.9	231.4	232.9	396.2	168.7	126.5	126.5	401.2	402.1	402.5	0.894	143.6	160.5	71.8	50.00	581.1	663.6	320.5
25	05/03/10	11:54:17	231.9	231.4	232.9	395.7	168.6	126.6	126.6	401.2	402.1	402.5	0.894	143.4	160.3	71.7	50.00	581.5	664.1	320.7
26	05/03/10	11:54:27	232.0	231.4	232.9	395.8	168.7	126.5	126.5	401.3	402.1	402.6	0.895	143.5	160.4	71.7	50.00	581.8	664.4	320.9
27	05/03/10	11:54:37	232.0	231.4	232.8	396.5	168.7	126.5	126.5	401.3	402.0	402.5	0.894	143.6	160.5	71.8	50.00	582.3	665.0	321.1
28	05/03/10	11:54:47	232.0	231.4	232.8	397.0	168.7	126.5	126.5	401.3	402.0	402.5	0.894	143.7	160.7	71.9	49.90	582.7	665.4	321.3
29	05/03/10	11:54:57	231.9	231.4	232.8	396.8	168.7	126.6	126.5	401.2	402.0	402.4	0.894	143.7	160.7	71.9	50.00	583.1	665.9	321.5
30	05/03/10	11:55:07	232.0	231.4	232.8	397.0	168.7	126.6	126.6	401.3	402.0	402.5	0.894	143.7	160.8	71.4	50.00	583.4	666.3	321.7

- In this LOG DATA page, click **HARMONICS DATA** at the bottom of the window to open the harmonics data for all current and voltage.

Exporting the Logged Data including Min/Max Events and Harmonics Data

The logged data can also be exported into excel sheet so that the Min-Max & event logs including the Harmonics can also be obtained in it such as shown below.

	D	E	F	G	H	I	J	K	L	M	N	O	P	Q	R
6478	238.89	241.74	241.74	333.81	268.09	326.68	325.91	325.99	325.89	416.23	418.69	416.23	42.72	0.893 LG	0.896 LG
6479	239.97	241.83	240.65	334.69	287.86	326.15	326.02	326.1	326	417.24	417.83	416.22	47.76	0.896 LG	0.892 LG
6480	239.5	241.28	241.62	334.34	288.26	325.99	325.91	325.99	325.88	416.36	418.19	416.65	45.74	0.894 LG	0.895 LG
6481	238.05	243.03	241.25	333.65	288.15	326.49	325.77	325.85	325.75	416.62	419.39	415.07	46.86	0.895 LG	0.897 LG
6482	239.14	242.53	240.67	333.75	287.79	326.87	325.95	326.04	325.93	417.13	418.45	415.52	44.71	0.894 LG	0.895 LG
6483	238.46	242.39	241.52	334.22	288.19	326.04	325.82	325.9	325.79	416.42	419.07	415.66	42.04	0.895 LG	0.895 LG
6484	239.49	242.71	240.1	333.79	288.32	326.17	325.94	326.02	325.91	417.59	418.11	415.32	46.13	0.897 LG	0.894 LG
6485	238.59	241.9	241.91	333.67	288.03	326.68	325.88	325.96	325.85	416.1	418.98	416.11	47.34	0.892 LG	0.897 LG
6486	237.77	242.91	241.69	334.05	287.52	326.9	325.75	325.83	325.72	416.27	419.66	415.21	43.13	0.893 LG	0.897 LG
6487	239.57	241.65	241.19	334.52	287.34	326.57	325.96	326.04	325.93	416.74	418.14	416.34	42.58	0.894 LG	0.892 LG
6488	237.87	243.18	241.27	333.75	288.09	326.57	325.75	325.84	325.72	416.59	419.53	414.94	41.66	0.895 LG	0.897 LG
6489	238.78	242.87	240.65	333.93	287.72	326.72	325.85	325.93	325.82	417.11	418.73	415.19	48.21	0.895 LG	0.895 LG
6490	239.08	240.97	242.31	334.52	287.16	326.77	325.79	325.87	325.75	415.72	418.52	416.88	43.75	0.892 LG	0.894 LG
6491	238.29	241.9	242.19	334.48	287.62	326.27	325.86	325.94	325.82	415.84	419.22	416.1	41.26	0.893 LG	0.896 LG
6492	239.09	242.62	240.65	333.64	287.82	326.75	325.89	325.98	325.86	417.16	418.51	415.45	43.78	0.894 LG	0.895 LG
6493	239.2	241.44	241.72	334.08	287.22	326.86	325.8	325.89	325.77	416.23	418.42	416.48	50.36	0.893 LG	0.894 LG
6494	239.35	240.89	242.04	334.56	287.22	326.48	325.82	325.91	325.8	415.89	418.22	416.88	41.76	0.893 LG	0.893 LG
6495	239.2	241.17	242.01	334.51	287.88	325.92	325.86	325.94	325.83	416	418.43	416.73	46.36	0.894 LG	0.894 LG
6496	238.18	242.67	241.52	333.86	288.27	326.07	325.77	325.85	325.74	416.42	419.31	415.42	43.27	0.895 LG	0.897 LG
6497	239.36	241.31	241.72	334.42	287.2	326.7	325.82	325.9	325.79	416.26	418.3	416.62	43.37	0.893 LG	0.893 LG
6498	238.82	241.29	242.22	334.37	287.75	325.97	325.77	325.85	325.74	415.78	418.72	416.58	47.24	0.893 LG	0.895 LG
6499	238.26	242.43	241.64	333.96	288.17	325.94	325.73	325.82	325.7	416.28	419.2	415.59	44.04	0.895 LG	0.896 LG
6500	237.85	243.08	241.39	333.54	288.22	326.3	325.68	325.77	325.66	416.49	419.55	415.02	46.15	0.894 LG	0.897 LG
6501	238.87	242.49	240.94	334.53	287.5	326	325.7	325.79	325.67	416.86	418.65	415.52	43.06	0.896 LG	0.893 LG
6502	238.4	242.67	241.35	334.41	287.92	325.82	325.61	325.71	325.59	416.61	419.16	415.46	45.44	0.896 LG	0.895 LG
6503	238.7	241.87	241.77	333.8	288.17	325.91	325.69	325.78	325.66	416.17	418.83	416.09	48.51	0.894 LG	0.896 LG
6504	239.14	241.88	241.25	333.77	287.74	326.55	325.72	325.8	325.69	416.66	418.39	416.02	44.8	0.894 LG	0.895 LG
6505	239.58	240.99	241.74	334.73	287.53	326	325.74	325.82	325.7	416.17	418.04	416.82	48.03	0.894 LG	0.892 LG
6506	239.51	242.37	240.37	334.02	288.03	325.7	325.7	325.79	325.67	417.31	418.05	415.58	44.15	0.896 LG	0.893 LG
6507	237.93	243.29	241.13	333.64	288.04	326.51	325.82	325.91	325.79	416.74	419.51	414.87	43.47	0.896 LG	0.897 LG
6508	238.13	242.01	242.21	333.46	287.64	326.81	325.88	325.96	325.84	415.8	419.33	415.97	43	0.891 LG	0.898 LG
6509	238.57	241.93	241.94	334.24	288.1	326.22	326.16	326.25	326.13	416.11	419.03	416.12	45.86	0.894 LG	0.896 LG
6510	239.39	241.67	241.29	333.76	288.05	326.45	326.05	326.14	326.02	416.6	418.24	416.27	46.4	0.895 LG	0.894 LG

Graph Representation

The graph plots for various selected parameters of Logged data including harmonics distortion along with date and time. Hence, the back ground color, Axis colors and Label colors can also be selectable.

Plotting a Graph for Logged data.

The logged data can be plotted to a graph with the selected parameters, date and time.

To plot a graph, proceed the following instructions,

1. At the top of the Logger Windows, click **Graph** to show a graph window.
2. At the bottom of the graph window, enter starting date and time in the **Start** box, enter ending date and time in **End** box under Date and Time. There are also two types of Scale such as Auto scale and Manual scale. Auto scale is already selected by default. For Manual scale requirement, select Manual scale.
3. To select for the parameters to be plotted, double-click in check box which will display the parameter selected at right side list with colors such as shown below.

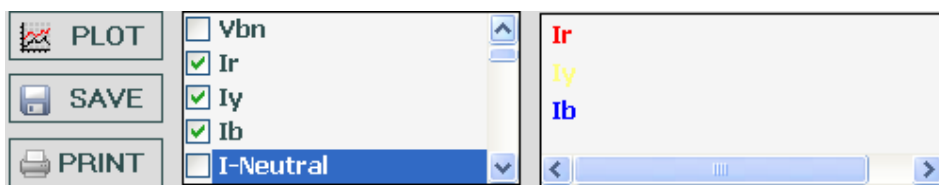

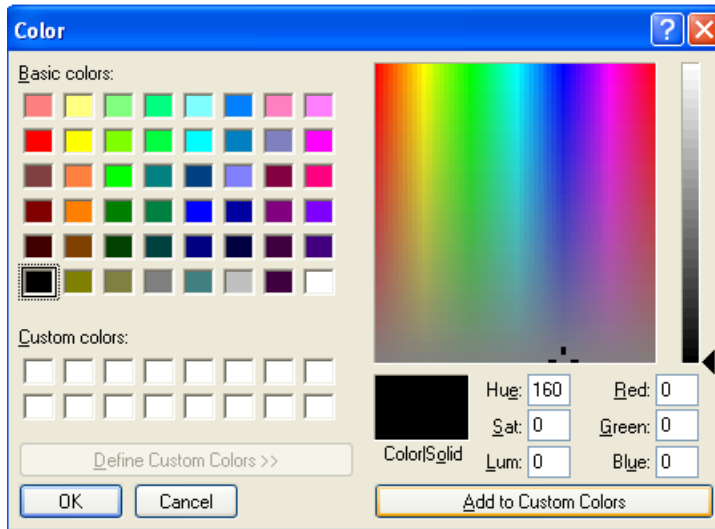

4. If the parameters selected are not desired, double-click again in the check box to remove the selected parameter from the list.
5. To change the color of the selected parameters displayed at right side list (e.g. Ir, Iy, Ib and KW) double-click on it, and then the color palette will show such as below.

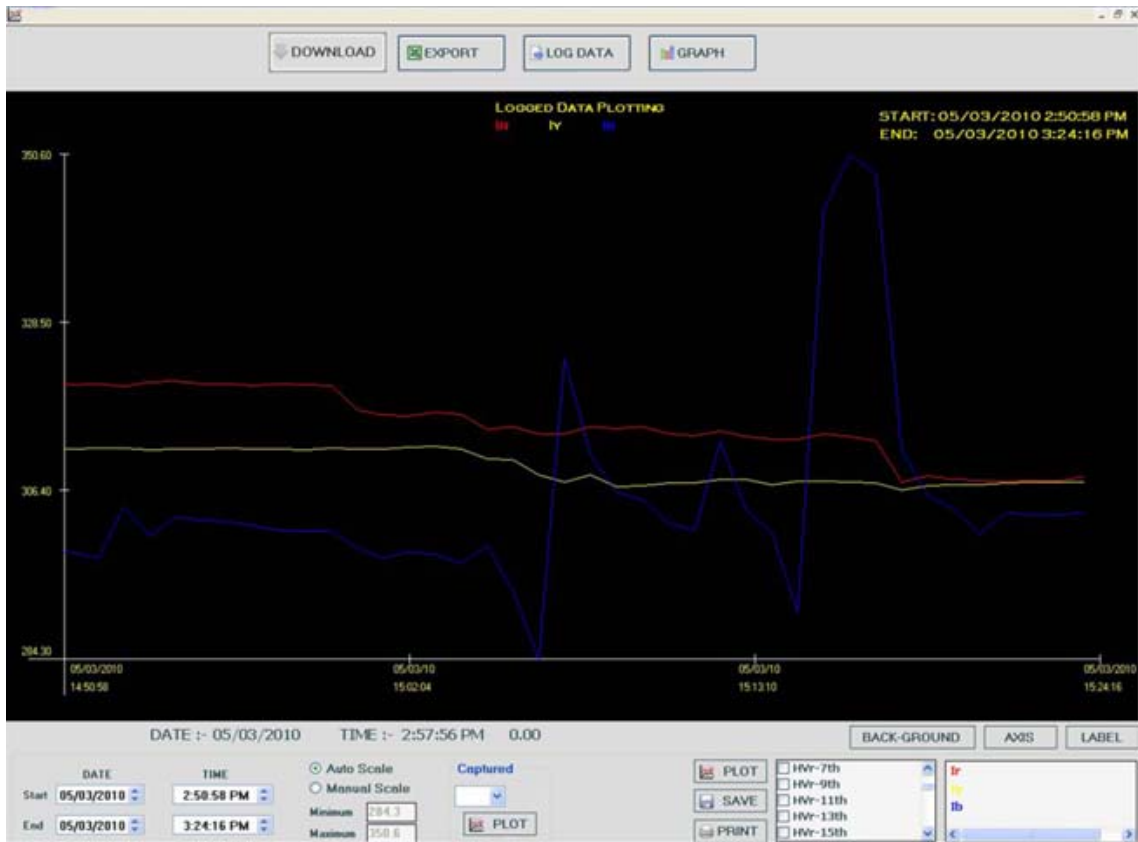

6. Select the desired color and click **Ok**. Now, the selected parameter will plot with the selected color. Similarly, each selected parameter can also be plotted. Before plotting the parameters, the background color, axis color and label color should be specified by clicking **BACK-GROUND**, **AXIS** and **LABEL** so as to represent along with the selected colors.
7. Now, click **PLOT** to plot a graph for the selected parameters such as shown below.



8. The plotted graphs can be saved and printed clicking  and  respectively. Hence, to return into previous Logger Windows, click .

Data Download Using a Pen Drive.



The unit supports pen drive for downloading logged data. The data exported as before into an excel sheet using a USB 2.0 can also be downloaded using a pen drive. Make sure your USB cable is disconnected.

Simultaneously, both USB and PEN DRIVE should not be used. First used port will keep on connecting only. The second port will not be responded because the unit will not support both the ports simultaneously.

To download data into a pen drive, follow the instructions:

1. Insert your pen drive into Pen-drive port provided at the top of the unit. Make sure your USB cable is disconnected. The unit will prompt a message such as shown below.

```
PEN DRIVE
DETECTED
Copy Data
to pen Drive?
No
```

2. Select YES by pressing  and  key and press  key to start downloading. The unit will prompt a message, "Downloading in pen drive" Wait for sometimes and download completely. It may take sometimes depending on the size of the logged data. If log has been recorded upto maximum 19691, it will take about 3 minutes.
3. After completing download, insert your pen drive into a pc and click **G-ddmmyy** (Goblin-date,month, year) folder and then click **GFhmmss.xls** (hour, minutes, second) file. It mentions date and time of data downloading according to RTC of the unit.
4. Now the excel sheet will open as previous excel sheet of data downloading using USB cable.

Programming Mode Using Utility

All the users' programmable parameters in Programming Mode of unit can also be programmed using Logger Utility. Using utility, user can easily specify for all the programmable parameters which is also more convenient than the programming in unit. Make sure USB cable coming from the PC is connected to Goblin where the USB port is provided at the top of the unit.

To configure the Programming Mode using Logger utility, proceed the following instructions

Double-click on the **Logger** icon as before. Now the Logger will open with the following window.

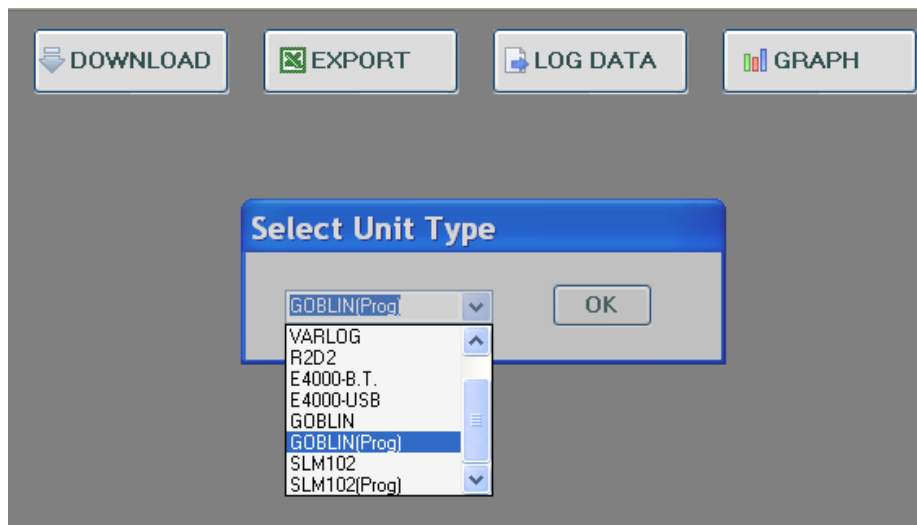

Select Goblin(Prog) in list box and click OK that will open the page such as shown below.

The screenshot displays the 'GOBLIN' configuration screen with the following sections and controls:

- Installation:** Radio buttons for 3P4W (selected) and 3P3W, with an APPLY button.
- CT-Ratio:** Input fields for mPRIMARY (5000), mSECONDARY (1), nPRIMARY (5000), and nSECONDARY (1), each with an APPLY button.
- PT-Ratio:** Input fields for PRIMARY (110) and SECONDARY (1), each with an APPLY button.
- Date & Time:** Digital input fields for DD, MM, YY, HH, MM, SS, with an APPLY button.
- LOG Duration:** Input field for MINUTE (1) with an APPLY button.
- Demand:** Input fields for WINDOW (Sliding-15) and RESET (Manual), each with an APPLY button.
- RS-485:** Radio buttons for 9600 (selected) and 19200, and an input field for UNIT ID (1) with an APPLY button.
- Relay:** Input fields for RELAY No. (1), PARAMETER (Volts), VALUE (5000), and HISTERISYS (05 %), each with an APPLY button.
- Event:** Input fields for EVENT No. (1), PARAMETER (Volts), VALUE (5000), and HISTERISYS (05 %), each with an APPLY button.
- RESETr:** Radio buttons for Reset Energy (selected), Reset Min/Max, Reset Logs, Reset MaxDemand, Reset Events, and Reset ALL, with an APPLY button.
- Verify Password:** Four empty input boxes followed by an APPLY button.
- Action Buttons:** APPLY ALL, READ ALL, and RESET METER buttons.

By default the cursor will blink in password box which shows user will enter password and enter the password used in meter and then, click **APPLY** to enter into Programming Mode. After configuring each programmable parameter, click **APPLY** to confirm the setting. If user selects Installation type and CT Ratio, the unit may restart. User will wait till the unit enters into Run Mode and then user will again enter password. In case, a message displays “Error In USB Communication” click **OK** and try again so that all the programmable parameter can be configured.

Control Outputs

The relay contacts provided in GOBLIN are rated for 3A @ 230VAC. They are also protected by snubbers against fast voltage transients which occur when inductive loads are switched off. Thus, the following points are to be taken care of when using these relay contacts:

1. Use 230VAC coils only in the contactors. DO NOT use 440V AC coils.
2. DO NOT switch small loads like electronic Hooters, small relays with 240V AC coils etc. directly from the relay contact of GOBLIN. If done so, the small leakage current from the snubbers will not allow these loads to be switched off fully. Thus, the electronic hooters will give a low hum continuously, and the small relays will switch on but not switch off. Use these relay contacts to switch an Auxiliary contactor and put the load on the contactor contacts.

Alarm Action

In Programming Mode, press  key till the unit enters into the following display:

```
>RELAY : 1          >RELAY : 2
  ALARM ON : KW      ALARM ON : PF
  ALARM VAL : 450    ALARM VAL : 955
  R_HYSTER : 5       R_HYSTER : 5
```

All relays, from 1 to 4, set Alarm On for the following parameters, Avg. Volts $[(Vry+Vyb+Vbr)/3]$, Avg. Amps $[(Ir+Iy+Ib)/3]$, KVA , KW , KVAR , Demand and PF. The value indicates the level at which the relay will close. E.g. If the Alarm On has been selected to KW, and the value is set to 450, the relay will close when the KW exceeds 450 and remains so for 1 minute. All parameters have this response time of 1 minute, except Demand which has a response time of 2 seconds. This is because Demand is already an integrated parameter.

Also, the switching ON logic of PF is reversed. For all parameters, the relay closed when the parameter value exceeds that defined by Value for more than one minute. In case of PF however, the relay will close when the PF falls below the Value and remains so for more than one minute. Also, the PF Value is entered with a multiplication factor of 1000. e.g. when the second alarm is set for PF and alarm Value is set to 955, the relay should close when the PF value falls below 0.955

The last parameter called Hysteresis defines the opening point for the relay which has closed in response to an alarm condition. This is specified as % of the Value. Thus, setting Hysteresis of 2 implies that the relay which closes when the parameter reaches Value, will open when the parameter falls below $0.98 \times \text{Value}$. This is done to prevent frequent operation / nuisance operation of the relay near the Value. E.g. If the Value has been set to 400, and Hysteresis to 5%, the relay will close when the parameter reaches 400 and then, the relay opens when it falls below 380. The

response times as outlined above for closing of relays also applies to opening of relays. Thus, the relay will open at 380 only if the parameter falls below 380 and remains so for 1 minute (2 seconds in case of Demand).

```
KW=17.27  
KVA=21.61  
KVAR=13.07  
PF=0.796
```

If all four relays are programmed to close on Demand and different values for closing and opening are set by the user, GOBLIN can be used effectively as a Maximum Demand Controller with four relay contacts!

Goblin as a Load Manager / Demand Management

Each relay can be programmed separately to generate alarm on a specific parameter with its specific value. The value at which it should open is also programmable. Thus, user could have the first relay programmed to close when the avg. Voltage exceeds certain value, second when the Avg. Amps exceeds some level, third for KW, or KVAR or PF or Demand and so on.

This allows the user to deploy *GOBLIN as a true LOAD manager*, to generate alarm / trip signals for four different conditions!

Appendix

Address Map of Various Parameters for 3P4W installation

Modbus Address	Parameters	Format	MF
40200	VIn-R	U-Long	100
40202	VIn-Y	U-Long	100
40204	VIn-B	U-Long	100
40206	VIn-Avg.	U-Long	100
40208	VII-RY	U-Long	100
40210	VII-YB	U-Long	100
40212	VII-BR	U-Long	100
40214	VII- Avg.	U-Long	100
40216	Ir	U-Long	100
40218	Iy	U-Long	100
40220	Ib	U-Long	100
40222	Iavg.	U-Long	100
40224	I-neutral	U-Long	100
40226	Future Use		
40228	Future Use		
40230	Hz	U-Long	100
40232	System PF	Long	1000
40234	PFR	Long	1000
40236	PFy	Long	1000
40238	PFb	Long	1000
40240	System KW	U-Long	100
40242	System KVAR	Long	100
40244	System KVA	U-Long	100
40246	KWr	U-Long	100
40248	KWy	U-Long	100
40250	KWb	U-Long	100
40252	Kvar-r	U-Long	100
40254	Kvar-y	U-Long	100
40256	Kvar-b	U-Long	100
40258	Kva-r	U-Long	100
40260	Kva-y	U-Long	100
40262	Kva-b	U-Long	100
40264	KW demand	U-Long	100
40266	MD-KW	U-Long	100
40268	KVA=Demand	U- Long	100
40270	MD-KVA	U-Long	100
40272	Future Use		
40274	Future Use		
40276	Sys-KWh	U-Long	100
40278	Sys-KVARh	U-Long	100
40280	Sys.-KVARh-LG	U-Long	100
40282	Sys.-KVARh-LD	U-Long	100
40284	Sys-KVAh	U-Long	100
40286	3rd Hvr	U-Long	10

40288	5th Hvr	U-Long	10
40290	7th Hvr	U-Long	10
40292	8th Hvr	U-Long	10
40294	9th Hvr	U-Long	10
40296	11th Hvr	U-Long	10
40298	15th Hvr	U-Long	10
40300	THD Hvr	U-Long	10
40302	3rd Hlr	U-Long	10
40304	5th Hlr	U-Long	10
40306	7th Hlr	U-Long	10
40308	8th Hlr	U-Long	10
40310	9th Hlr	U-Long	10
40312	11th Hlr	U-Long	10
40314	15th Hlr	U-Long	10
40316	THD Hlr	U-Long	10
40318	3rd Hvy	U-Long	10
40320	5th Hvy	U-Long	10
40322	7th Hvy	U-Long	10
40324	8th Hvy	U-Long	10
40326	9th Hvy	U-Long	10
40328	11th Hvy	U-Long	10
40330	15th Hvy	U-Long	10
40332	THD Hvy	U-Long	10
40334	3rd Hly	U-Long	10
40336	5th Hly	U-Long	10
40338	7th Hly	U-Long	10
40340	8th Hly	U-Long	10
40342	9th Hly	U-Long	10
40344	11th Hly	U-Long	10
40346	15th Hly	U-Long	10
40348	THD Hly	U-Long	10
40350	3rd Hvb	U-Long	10
40352	5th Hvb	U-Long	10
40354	7th Hvb	U-Long	10
40356	8th Hvb	U-Long	10
40358	9th Hvb	U-Long	10
40360	11th Hvb	U-Long	10
40362	15th Hvb	U-Long	10
40364	THD Hvb	U-Long	10
40366	3rd Hlb	U-Long	10
40368	5th Hlb	U-Long	10
40370	7th Hlb	U-Long	10
40372	8th Hlb	U-Long	10
40374	9th Hlb	U-Long	10
40376	11th Hlb	U-Long	10
40378	15th Hlb	U-Long	10
40380	THD Hlb	U-Long	10

Address Map of Various Parameters for 3P3W installation

Modbus Address	Parameters	Format	MF	
40200	VRY	U-Long	100	
40202				0
40204	VYB	U-Long	100	
40206				0
40208				0
40210				0
40212				0
40214	VII- Avg.	U-Long	100	
40216	Ir	U-Long	100	
40218	Iy	U-Long	100	
40220	Ib	U-Long	100	
40222	Iavg.	U-Long	100	
40224	I neutral	U-Long	100	
40226	System use. Ignore data.			
40228	System use. Ignore data.			
40230	Hz	U-Long	100	
40232	System PF	Long	1000	
40234				0
40236				0
40238				0
40240	System KW	U-Long	100	
40242	System KVAR	Long	100	
40244	System KVA	U-Long	100	
40246				0
40248				0
40250				0
40252				0
40254				0
40256				0
40258				0
40260				0
40262				0
40264	KW demand	U-Long	100	
40266	MD-KW	U-Long	100	
40268	KVA=Demand	U-Long	100	
40270	MD-KVA	U-Long	100	
40272	System use. Ignore data.			
40274	System use. Ignore data.			
40276	Sys-KWh	U-Long	100	
40278	Sys-KVARh	U-Long	100	
40280	Sys-KVARh- LG	U-Long	100	

40282	Sys-KVARh - LD	U-Long	100	
40284	Sys-KVAh	U-long	100	
40286	3rd Hvr	U-Long	10	
40288	5th Hvr	U-Long	10	
40290	7th Hvr	U-Long	10	
40292	8th Hvr	U-Long	10	
40294	9th Hvr	U-Long	10	
40296	11th Hvr	U-Long	10	
40298	15th Hvr	U-Long	10	
40300	THD Hvr	U-Long	10	
40302	3rd Hlr	U-Long	10	
40304	5th Hlr	U-Long	10	
40306	7th Hlr	U-Long	10	
40308	8th Hlr	U-Long	10	
40310	9th Hlr	U-Long	10	
40312	11th Hlr	U-Long	10	
40314	15th Hlr	U-Long	10	
40316	THD Hlr	U-Long	10	
40318				0
40320				0
40322				0
40324				0
40326				0
40328				0
40330				0
40332				0
40334				0
40336				0
40338				0
40340				0
40342				0
40344				0
40346				0
40348				0
40350	3rd Hvb	U-Long	10	
40352	5th Hvb	U-Long	10	
40354	7th Hvb	U-Long	10	
40356	8th Hvb	U-Long	10	
40358	9th Hvb	U-Long	10	
40360	11th Hvb	U-Long	10	
40362	15th Hvb	U-Long	10	
40364	THD Hvb	U-Long	10	
40366	3rd Hlb	U-Long	10	
40368	5th Hlb	U-Long	10	
40370	7th Hlb	U-Long	10	
40372	8th Hlb	U-Long	10	
40374	9th Hlb	U-Long	10	
40376	11th Hlb	U-Long	10	
40378	15th Hlb	U-Long	10	
40380	THD Hlb	U-Long	10	

NOTES

For providing resolution, all parameters except PF are multiplied with 100 before transmitting. Thus if the KVA value is 278.99, it is sent out as 27899. PF has a MF of 1000, instead of 100. Thus, a PF value of 0.987 is sent as 987.

If an attempt is made to read from some address other than the valid addresses, the exception response is sent.

EXCEPTION CODE

In the event that the query from the HOST has no communication error, but there is some error in specifying the address of register to be read, the meter return in exception message. The format of the exception message will be under:

Unit address 0*83 Exception code CRC CRC

Exception code can have only one value:

If the address is not a valid start address or host has requested more than 32 bytes of the data, this code is return.

P.O No. :

Customer :

Sr. No. :

Routine and function tests conducted to relevant standards and our Specifications/Literature/O & M Manual.

Traceability: tested against "MTE" Standard Model PRS400.3 having basic accuracy of 0.02% traceable upto International Standards derived using appropriate ratio techniques.

Result of Test :

Remarks :

Test engineer :

Date :
